

## Technical data sheet – Starscreen 3-mal

Starscreen 3 fractions, version mobile

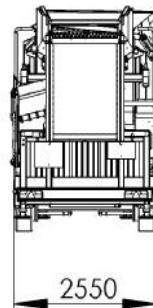
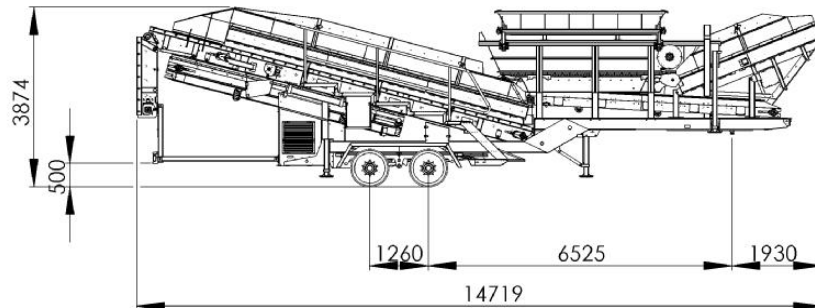

Copyright by ISO 16016!

### General

<b>Throughput capacity:</b>	max. up to 300 t or 200 m <sup>3</sup> per hour
<b>Weight:</b>	max. 25 t
<b>Construction form:</b>	Trailer according to Road Traffic Regulation
<b>Acceptances:</b>	CE declaration / vehicle registration according to German road regulation (*)

### Hopper

<b>Material to be conveyed:</b>	All forms of bulk material, compost, earth, rubbish etc. We recommend in cases of foreign pieces like stones, iron, bigger than 400 mm a prior use of bar grid / vibration grid
<b>Capacity volume:</b>	5.00 m <sup>3</sup>
<b>Hopper dimension:</b>	1.20 m x 3.90 m
<b>Loading height:</b>	3.35 m
<b>Drive:</b>	Spur gears / Danfoss OM
<b>Conveying speed:</b>	Infinitely adjustable, automatic switch on / off in the event of overload.
<b>Auger:</b>	Optional infinitely adjustable to achieve an optimum charging of the material. Use in compost, bark, etc.
<b>Belt width:</b>	1.20 m
<b>Profiling:</b>	Profiled belt with smooth surface

### Starscreen

<b>Starscreen fraction:</b>	<b>Fraction I:</b> 50 – 120 mm <b>Fraction II:</b> 0-35 mm depends on customer request
<b>Starscreen dimension:</b>	<b>Screendeck I:</b> 1.20 m x 5.10 m <b>Screendeck II:</b> 1.20 m x 6.70 m
<b>Drive:</b>	Danfoss OMS, high-quality roller chain with hardened, galvanized double sprockets
<b>Bearing:</b>	High quality flange bearings; bearing size depends on screening size. To get a longer life the bearings are provided with dots of central lubrication.
<b>Chain protection:</b>	folding sidewise

### Fine conveyor belt

(left hand side)

<b>Dimension:</b>	0.65 m x 5.10 m
<b>Conveying speed:</b>	Infinitely adjustable
<b>Belt width:</b>	0.65 m
<b>Profiling:</b>	Smooth
<b>Drive:</b>	Danfoss OM



## Technical data sheet – Starscreen 3-mal

Starscreen 3 fractions, version mobile

### Middle conveyor belt (\*)

(backward)

<b>Dimension:</b>	1.20 m x 3.60 m
<b>Conveying speed:</b>	Infinitely adjustable
<b>Belt width:</b>	1.20 m
<b>Profiling:</b>	Smooth
<b>Drive:</b>	Danfoss OM

### Underbelt (\*)

<b>Dimension:</b>	1.20 m x 5.40 m
<b>Conveying speed:</b>	Infinitely adjustable
<b>Belt width:</b>	1.20 m
<b>Profiling:</b>	Smooth
<b>Drive:</b>	Danfoss OM

### Motor specification

<b>Manufacturer:</b>	Perkins / 1106D - E66TA
<b>Type:</b>	1106
<b>Output:</b>	168 kW gross / 158 kW net
<b>Emission standard:</b>	Certified as latest standard
<b>Cooling:</b>	Water cooled
<b>Diesel tank:</b>	380 litres

### Electrical control

<b>Presentation:</b>	Graphical CAN-BUS colour display 6.5 “
<b>Function:</b>	With integrated CAN-BUS piloting system
<b>Operator switching cabinet:</b>	0.50 m x 0.50 m x 0.21 m
<b>Operation:</b>	Via manual operation / if preferred, radio remote control (*)
<b>Description:</b>	simple use by to automatic start-stop program

### Hydraulics

<b>Pump:</b>	Bosch – Rexroth A10V0 Tandem / Triplex combination (*)
<b>Valves:</b>	Danfoss PVG 32
<b>Cooling:</b>	Hydraulic air cooling system
<b>Hydraulic tank:</b>	250 litres
<b>Description:</b>	Safety device through level switching off in case of losing hydraulic oil.

### Running gear

<b>Tires:</b>	385 / 55 R22.5
<b>Brakes:</b>	Knorr ABS / EBS sensitised.
<b>Axles:</b>	Tandem axle BPW / SAF max. 9 t per axle
<b>Suspension:</b>	Air suspension

### Varnishing:

<b>Priming:</b>	Eposist varnish
<b>Final varnishing:</b>	PU – finish varnish
<b>Colour tone:</b>	House colour RAL 1007, optional in other colour tones available (*)

\*(optional ordering possibility)

