

Technical data sheet - Starscreen machine 2-ta

Starscreen 2 fractions, version track mobile

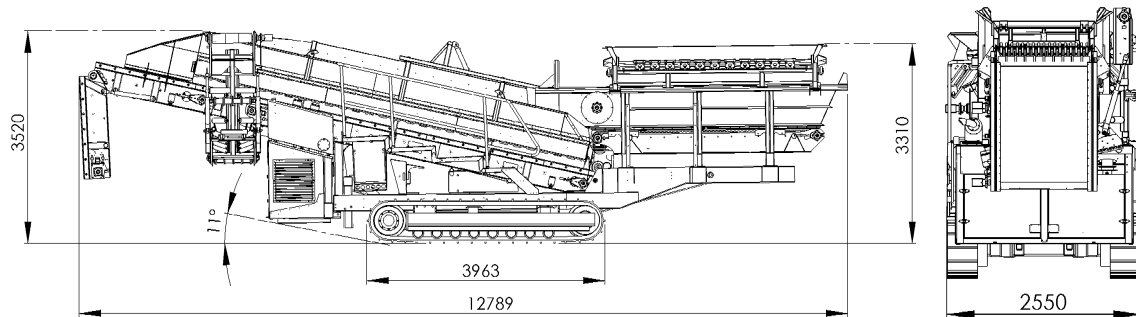

Copyright by ISO 16016!

General

Throughput capacity:	max. up to 200 m ³ per hour
Weight:	max. 18 t
Construction form:	Tracks
Acceptances:	CE declaration / vehicle registration according to German road regulation. (*)

Hopper

Material to be conveyed:	All forms of bulk material, compost, earth, rubbish etc. We recommend in cases of foreign pieces like stones, iron bigger than 400 mm a prior use of bar grid / vibration grid
Capacity volume:	5.00 m ³
Hopper dimensions:	0.80 m x 1.88 m x 3.90 m
Loading height:	2.90 m
Drive:	Spur gears / Danfoss OM
Conveying speed:	Infinitely adjustable, automatic switch on / off in the event of overload.
Auger:	Optional infinitely adjustable to achieve an optimum charging of the material. Use in compost, bark, etc
Belt width:	1.20 m
Profiling:	Profiled belt with smooth surface

Starscreen:

Starscreen fraction:	8 mm – 80 mm depends on customer request
Starscreen dimension:	1.20 m x 6.70 m
Drive:	Danfoss OMS, high-quality roller chain with hardened, galvanized double chain wheels
Bearing:	High quality flange bearings; bearing size depends on screening size. To get a longer life the bearings are provided with dots of central lubrication. (*)
Chain protection:	folding sidewise

Fine conveyor belt

(right hand side)	
Dimensions:	0.65 m x 5.10 m
Conveying speed:	Infinitely adjustable
Belt width:	0.65 m
Profiling:	Smooth
Drive:	Danfoss OM

Technical data sheet - Starscreen machine 2-ta

Starscreen 2 fractions, version track mobile

Over fraction belt (*)

(backward)

Dimensions:	1.20 m x 3.60 m
Conveying speed:	Infinitely adjustable
Belt width:	1.20 m
Profiling:	Smooth
Drive:	Danfoss OM

Motor specification

Manufacturer:	Perkins / 1106D - E66TA
Type:	1106
Output:	130 kW gross / 122 kW net
Emission standard:	Certified as latest standard
Cooling:	Water cooled
Diesel tank:	380 litres

Electrical control

Presentation:	Graphical CAN-BUS colour display 6.5 “
Function:	With integrated CAN-BUS piloting system
Operator switching cabinet:	0.50 m x 0.50 m x 0.21 m
Operation:	Via manual operation / if preferred, radio remote control (*)
Description:	simple use by automatic start – stop program

Hydraulics

Pump:	Bosch – Rexroth A10V0 Tandem / Triplex combination (*)
Valves:	Danfoss PVG 32
Cooling:	Hydraulic air cooling system
Hydraulic tank:	250 litres
Description:	Safety device through level switching off in case of losing hydraulic oil

Tracks:

Dimension:	3.95 m length, 0.40 m width Machine is hydraulic retractable, the track is driven by remote control
-------------------	--

Varnish:

Priming:	Eposist varnish
Final varnish:	PU – finish varnish
Colour tone:	House colour RAL 1007, optional in other colour tones available (*)

*(optional ordering possibility)